



aerospace  
climate control  
electromechanical  
**filtration**  
fluid & gas handling  
hydraulics  
pneumatics  
process control  
sealing & shielding



## Portable Filter Carts

Models 5MFP & 10MFP with Moduflow™ *Plus*  
and Intelli-Cart™



ENGINEERING YOUR SUCCESS.

# Portable Filter Carts

## Applications

- **Filtering new fluid before putting into service**
- **Transferring fluid from drums or storage tanks to system reservoirs**
- **Conditioning fluid that is already in use**
- **Complimenting existing system filtration**
- **Removing free and emulsified water from a system**
- **For use with fluids such as hydraulic, gear and lube oils**

Parker portable filter carts are the ideal way to prefilter and transfer fluids into reservoirs or to clean up existing systems.

Fluid should always be filtered before being put into use. New fluid is not necessarily clean fluid. Most new fluids (right out of the drum) are unfit for use due to high initial contamination levels. Contamination, both particulate and water, may be added to a new fluid during processing, mixing, handling and storage.

Water is removed by installing Par-Gel™ elements in the outlet filter. Par-Gel™ elements are made from a polymer which has a very high affinity for free water.

Once water comes into contact with this material, it is removed from the system.

The Parker portable filter cart uses two high capacity ModuFlow™ Plus filters for long element life and better system protection. The first stage (inlet) filter captures larger particles, while the second stage (outlet) filter captures finer particles or removes water. A rugged industrial quality gear pump gets the job done fast.

Using a Parker portable filter cart is the most economical way to protect your system from the harm that can be caused by contamination.

Features	Advantages	Benefits
<ul style="list-style-type: none"> <li>• Two filters instead of one w/ 2.5 times increased dirt holding capacity</li> </ul>	<ul style="list-style-type: none"> <li>• Pump protection and long element life</li> </ul>	<ul style="list-style-type: none"> <li>• Element cost savings and trouble-free service</li> </ul>
<ul style="list-style-type: none"> <li>• Wide variety of particulate elements available</li> </ul>	<ul style="list-style-type: none"> <li>• Capable of getting a fluid to a desired cleanliness level</li> </ul>	<ul style="list-style-type: none"> <li>• Extends fluid life and system performance</li> </ul>
<ul style="list-style-type: none"> <li>• Par-Gel™ water removal elements available</li> </ul>	<ul style="list-style-type: none"> <li>• Removes “free water” from a system</li> </ul>	<ul style="list-style-type: none"> <li>• Gets dirt and water out of system with one process</li> </ul>
<ul style="list-style-type: none"> <li>• Heavy duty frame</li> </ul>	<ul style="list-style-type: none"> <li>• Rugged and durable</li> </ul>	<ul style="list-style-type: none"> <li>• Built to last</li> </ul>
<ul style="list-style-type: none"> <li>• Lightweight and portable</li> </ul>	<ul style="list-style-type: none"> <li>• Easy to move from place-to-place</li> </ul>	<ul style="list-style-type: none"> <li>• One person operation</li> </ul>
<ul style="list-style-type: none"> <li>• Two flow rates available: 5 gpm or 10 gpm</li> </ul>	<ul style="list-style-type: none"> <li>• Enables use in low or high viscosity applications</li> </ul>	<ul style="list-style-type: none"> <li>• Matched to your needs</li> </ul>
<ul style="list-style-type: none"> <li>• Eleven-foot hose and wand assemblies included</li> </ul>	<ul style="list-style-type: none"> <li>• Additional hardware not necessary</li> </ul>	<ul style="list-style-type: none"> <li>• Ready to use as received</li> </ul>

# Portable Filter Carts

## Applications

### Hose & wand assembly

- Ready to use; no additional hardware needed
- Flexible hoses for tight spots
- Kink-resistant hose prevents pump cavitation

### Visual indicator

- Tells you when to change element

### Heavy Duty frame

- Rugged and built to last

### Dual filters

- Two stage, double length filtration for long element life and pump protection

### Elements (not shown)

- Available for both particulate and Water Removal (WR) in double length w/ 2.5 times increased dirt holding capacity

### icountPD (Intelli-Cart™ option)

- Early warning LED or digital display indicators for Low, Medium and High contamination levels
- Self diagnostic software

### Service cover

- Top-accessible for easy changing of elements

### Electrical Cord

- 6 ft. with ON/OFF switch
- Optional 20 ft. cord with retractable reel & mounted power switch with thermal overload protection

### 110V/220V AC motor

- Industrial brand name

### Gear pump

- Industrial quality
- Quiet operation
- Dependable, long life

### Drip tray

- Helps keep the work area safe and clean

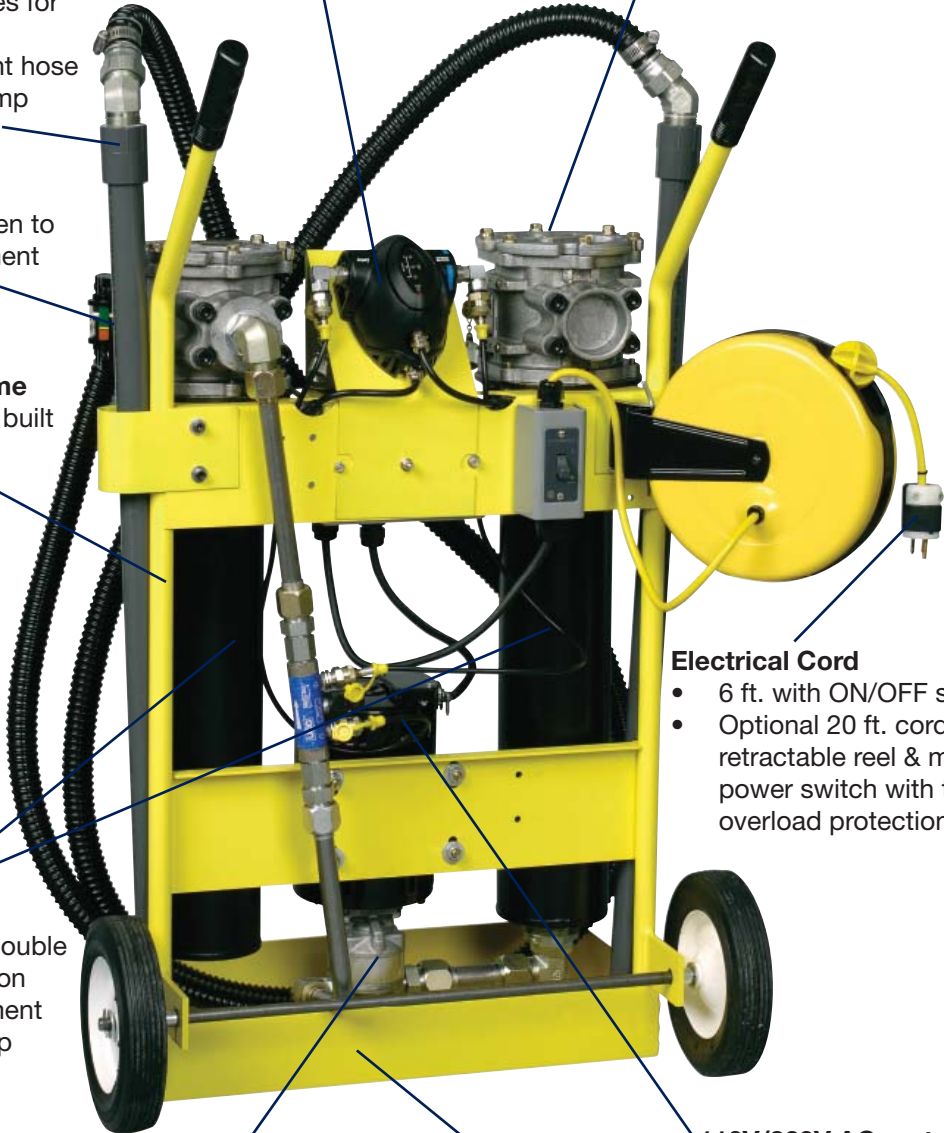

# Portable Filter Carts

## Specifications

### Maximum Recommended Fluid

#### Viscosity:

5MFP – 3000 SUS (647cSt)  
0.85 specific gravity

10MFP – 500 SUS (108 cSt)  
0.85 specific gravity

#### Visual Indicator (outlet filter):

Visual differential type  
3-band (clean, change, bypass)

#### Filter Bypass Valve Settings

##### (Integral to Element):

Inlet – 3 psid (0.2 bar)  
Outlet – 35 psid (2.4 bar)

#### Operating Temperature:

Seal option “B” (standard)  
-40°F to +150°F (-40°C to +66°C)

### Electrical Service Required:

5MFP – 110/220 volts, 60/50  
Hz, single phase, 8/4 amps  
10MFP – 110/220 volts, 60/50  
Hz, single phase, 10/5 amps

#### Electrical Motor:

5MFP – ½ hp @ 1725 rpm,  
Open, Drip Proof  
10MFP – ¾ hp @ 3450 rpm,  
Open, Drip Proof  
Thermal overload protection

### Construction:

Cart frame – Steel  
Filter head – Aluminum  
Filter bowl – Steel  
Hoses – PVC (Std.)  
EPDM (high temp option)  
Wands – PVC (Std.)  
Steel tube (high temp  
option)

### Weight:

110 lbs. (45.4kg)

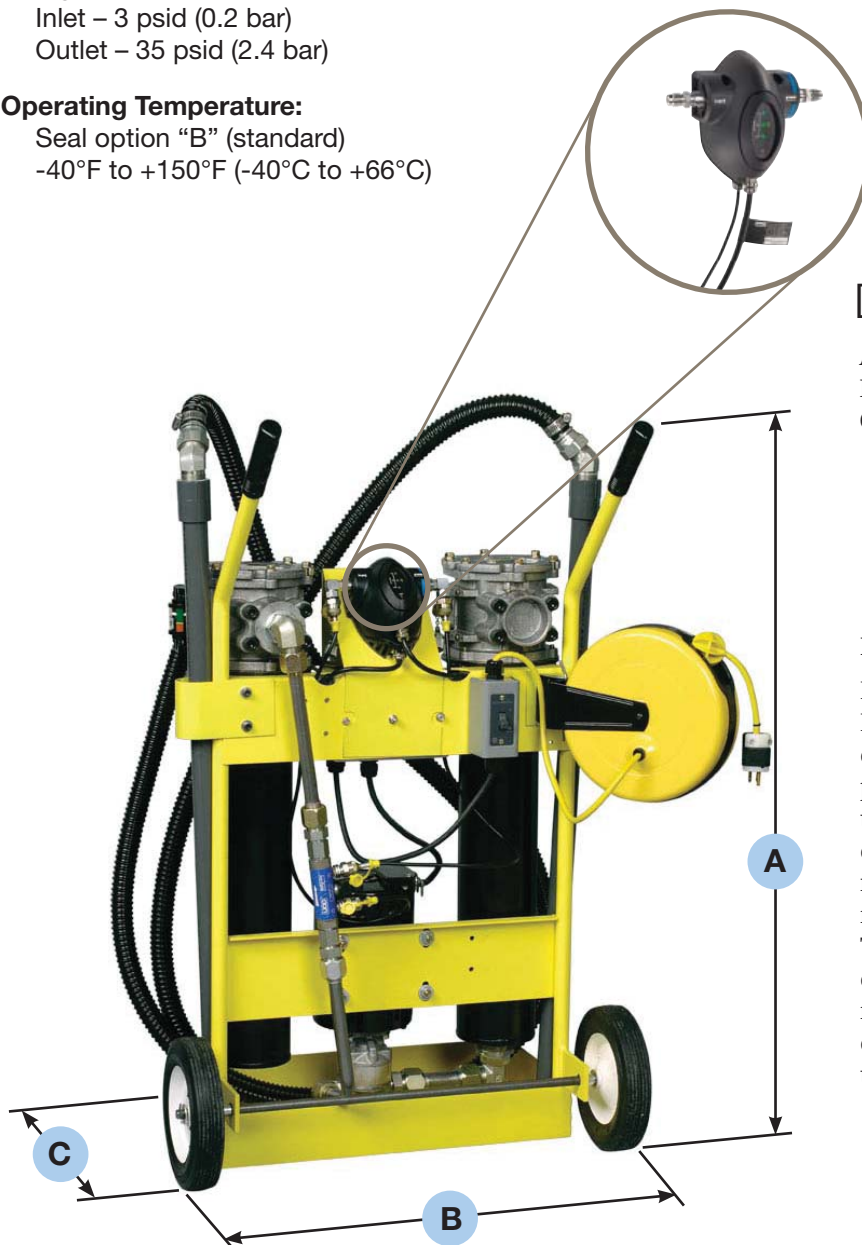

## Dimensions:

A = Height: 1034mm (40.7 in.)  
B = Width: 648mm (25.5 in.)  
C = Depth: 503mm (19.8 in.)

## New feature!

### Intelli-Cart™

Parker is pleased to announce its R&D effort to offer a diagnostic filter cart - the Intelli-Cart. The icountPD particle detector, the most up-to-date technology in solid particle detection, can be mounted to the standard frame of the filter cart for enhanced monitoring of your hydraulic system. The icountPD, coupled with the filter cart is a cost effective solution to fluid management and contamination control. Ask your sales representative today for more information.



# Typical Fluid Cleanliness Level Requirements

Many manufacturers of hydraulic components have established fluid cleanliness levels for their components. Using a portable filter cart can be a very effective way to reach and maintain these cleanliness levels.

Component	ISO Cleanliness Level
Servo control valves	16/14/11
Proportional valves	17/15/12
Vane and piston pumps/motors	18/16/13
Directional and pressure control valves	18/16/13
Gear pumps/motors	19/17/14
Flow control valves cylinders	20/18/15
New fluid	20/18/15

# Filter Cart Element Performance

Media Code	Filter Media	Capacity (Grams)
40W	Woven Wire	*
40SA	Synthetic	*
20Q	Microglass III	140
10Q	Microglass III	135
05Q	Microglass III	130
02Q	Microglass III	110

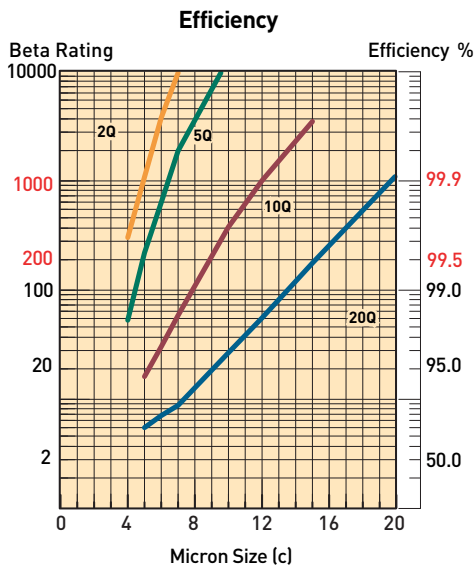

Notes: Multipass test run @ 80 gpm to 50 psid terminal - 5 mg/l BUGL.

# Filter Cart Performance

Fluid cleanliness levels are a function of initial contamination levels, contamination ingress rates, reservoir size and filter element efficiency. The chart below lists approximate time requirements to achieve certain cleanliness levels based on the assumptions noted.

Reservoir Capacity (Gallons)	Time Required (Hours)	Projected Cleanliness Level (ISO)
50	0.5	20/18/15
50	1.0	17/15/12
50	2.5	16/14/11
100	1.5	18/16/13
100	2.5	17/15/12
100	4.0	16/14/11
200	2.5	19/17/14
200	3.5	18/16/13
200	5.0	17/15/12

Notes:

The results in the chart are based on the following assumption:

1. Initial contamination level is 500,000 particles greater than 10 micrometers per 100 ml of fluid (10MFP cart).
2. Inlet filter fitted with 40SA element; outlet with 20Q element.
3. System ingress rate equal to  $1 \times 10^6$  particles greater than 10 micrometers entering the system per minute.

The Intelli-Cart™ with particle detector provides an excellent method for filtering and trending contamination levels.

For optimum particle detector performance results when monitoring contamination levels, fluid viscosity range should be 50 - 250 SUS.

# Par-Gel™ Media Water Capacity

Model	Fluid Viscosity	Capacity
5MFP	75 SUS	600 ml
	200 SUS	420 ml
10MFP	75 SUS	500 ml
	200 SUS	300 ml

Notes:

1. Par-Gel™ elements are designed to remove “free water”, which is defined as water that is above a particular fluid’s saturation level.
2. Capacity is very dependent on flow rate and viscosity. Not recommended with fluids in excess of 500 SUS.

## Assembly

1. Install hoses to inlet and outlet filters by threading the hose end with the straight thread o-ring seal fitting into the filter flange.
2. Connect the PVC tube wands to the swivel fitting on the hose end. When servicing the PVC tube wand, do not over-torque the metal fittings going into the PVC coupling. Over-torque will result in cracking the coupling. Generally, 1/4 turn beyond hand-tight is sufficient.
3. The Intelli-Cart™ is shipped with a bag that contains user manuals, iPD programming disk, and accessory parts.
4. The iPD is shipped with the factory default setting. Users can reprogram the iPD with the cable located in the attached bag, the program disk and the iPD owners manual.

## Operating Instructions

1. Insert the inlet wand assembly into the supply fluid receptacle (drum/reservoir). The RFP filter is the inlet filter.
2. Insert the outlet wand assembly into the clean fluid receptacle (drum/reservoir). The ILP filter is the outlet filter.
3. Verify that the ON/OFF switch is OFF and plug the cord into the proper grounded power source (3 wire).
4. Turn switch to ON position and check outlet wand for oil flow. Allow 30 to 60 seconds for filters to fill with oil. If repeated attempts to obtain oil flow fail, check pump inlet fittings for tightness, remove inlet filter access cover and verify the cover sealing o-ring is in place. For very viscous fluids it may be necessary to pour 1 or 2 quarts of fluid into the RFP inlet filter housing to prime pump initially.
5. The condition of the filter element should be monitored by observing the cleanliness indicator on the outlet filter. When the indicator is in the CHANGE position, both inlet

and outlet filter elements MUST be replaced to prevent fluid from going through the bypass in the filters.

6. The inlet filter element is provided with a 3PSI bypass spring, and prevents the pump from cavitating if the element is not changed. The outlet filter element is provided with a 35PSI bypass spring to prevent excessive pressure which may be harmful to personnel or to the filter cart.

**Warning:** The filter bypass spring acts as a relief valve for the pump. Do not restrict the outlet hose with a shut-off valve which will defeat the function of the bypass valve, causing excessive pressure, which may be harmful to personnel or to the filter cart.

7. The cleanliness indicator works on differential pressure and will indicate the condition of the element (CLEAN, CHANGE, or BYPASS).

**NOTE:** The filter cart must be in operation for the indicator to read properly.

## Maintenance Instructions

1. Turn switch to OFF position and unplug cord from electrical outlet.

2. Remove tube wands from oil to prevent siphoning.
3. Loosen hex head screws on filter cover. Turn cover to clear screws, remove cover.
4. Pull filter element from the filter head.
  - a) Replace the synthetic or Microglass III elements. Verify correct element replacement.
  - b) Wire mesh elements can be cleaned. Ultrasonic cleaners provide best results.
5. Install element in filter housing. Make sure element o-rings seat properly into the head, making sure that the notch on the element lines up with the notch in the head.
6. Inspect the cover o-ring and replace if necessary.
7. Replace cover and tighten hex head screws until they are snug. Do not over-torque (16 - 19 Ft. Lbs.) these screws. Do not interchange the inlet filter cover with the outlet filter cover. (The inlet filter has a "RFP" prefix, the outlet filter has a "ILP" prefix).
8. Contact the HFD service department at 419-644-0259 regarding iPD calibration.
9. iPD removal: remove oil lines from the iPD at the two fittings closest to the iPD. Disconnect the two cables from the iPD. Remove iPD from cart via two screws. The cart can be used without the iPD as long as the sample hoses are removed from the System 20. Protect sampling connectors from contamination.

## Trouble Shooting

Problem	Cause	Solution
Does not start	ON/OFF Switch No electrical power Defective motor	Turn switch ON, replace switch if defective Plug in cart Replace
No oil flow or erratic pump noise	Filter housing not filled with oil Suction leak  Defective pump	Allow pump to run 30 to 60 seconds Check tightness of inlet fittings Check o-ring in inlet filter cover for nicks Kink or restriction in inlet hose Add 1 or 2 quarts of oil to inlet filter Replace pump
Indicator reads CHANGE or BYPASS	Element dirty Oil extremely cold or viscous	Replace or clean elements (both filters) Change element to coarser micron rating
Indicator does not seem to move	No outlet element 40 micron element installed in outlet filter	Install element Check cart model number to verify correct element. The inlet filter has a rating RFP prefix; the outlet filter has an ILP prefix

# Filter Cart Replacement Parts

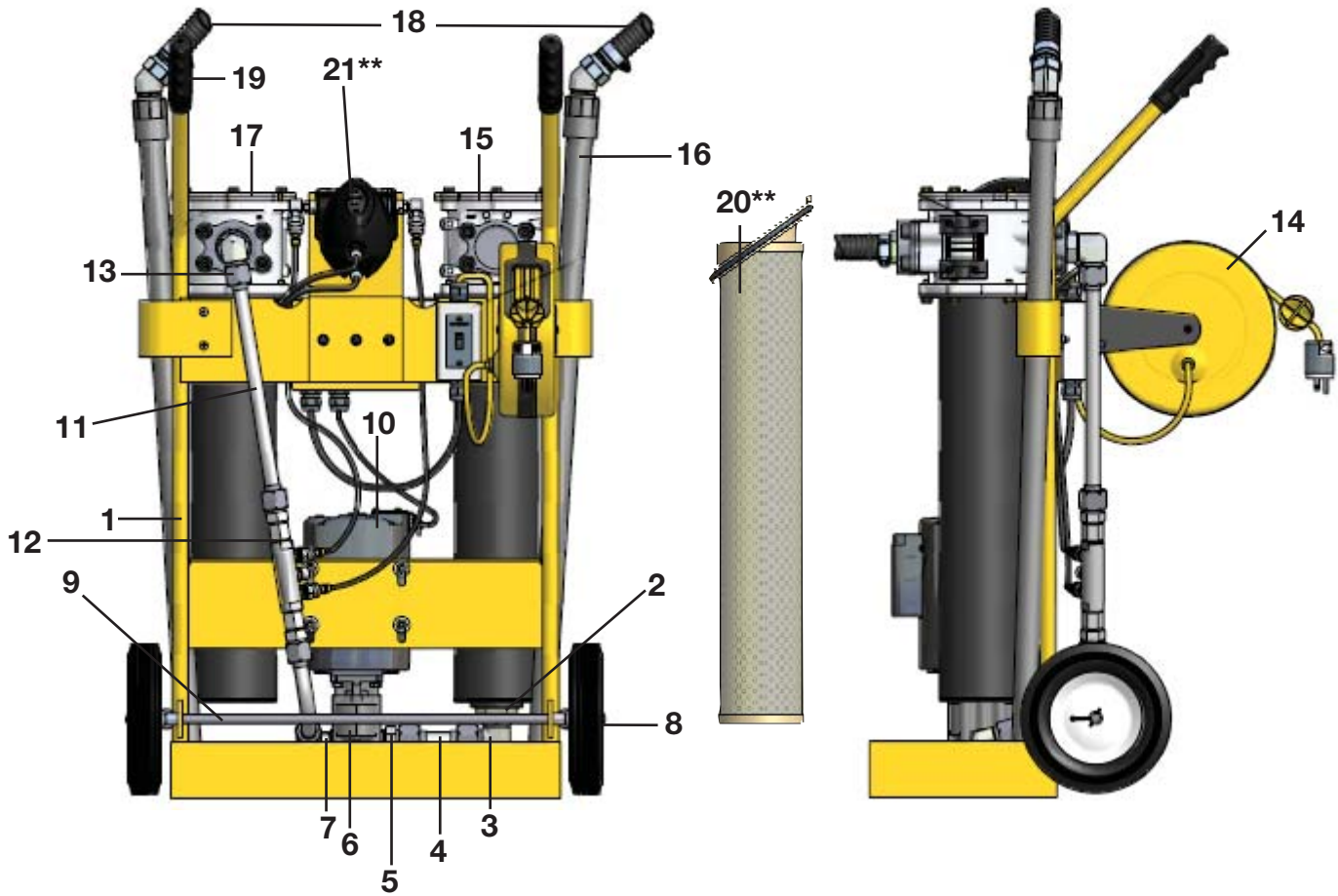

Item No.	Part No.	Description	Qty
1	928690	Frame	1
1	941468	Frame (Intelli-Cart™)	1
2	940980	Pipe Reducer Fitting	1
3	940979	Tube Fitting	1
4	937526	Suction Tube Assy.	1
5	928652	Adapter Fitting	1
6	928731	Pump	1
7	940977	Adapter Fitting	1
8	928650	Wheel	2
9	928653	Axle	1
10	928678	Motor 10MFP	1
10	929692	Motor 5MFP	1
11	937527	Discharge Tube Assy.	1
12	941467	Discharge Tube Top (Intelli-Cart™)	1
	941466	Discharge Tube Bottom (Intelli-Cart™)	1
	STI.0144.100	System 20 (Intelli-Cart™)	1
	3/8-8F40HG5S	System 20 Fitting 1 (Intelli-Cart™)	2
	12/8 F50X-S	System 20 Fitting 2 (Intelli-Cart™)	2

Item No.	Part No.	Description	Qty
13	940978	Tube Fitting	1
14	928623	Cord Reel	1
15	940960	Inlet Filter – Nitrile	1
15	941024	Inlet Filter – Fluorocarbon	1
16	928784	Tube Wand Assy. – Seal Option B	2
17	940961	Outlet Filter – Nitrile	1
17	941025	Outlet Filter – Fluorocarbon	1
18	928663	Hose Assy. – Seal Option B	2
19	928651	Handle Grip	2
20	See Chart**	Element, (1) Inlet & (1) Outlet	2
21	See Chart**	icountPD (Intelli-Cart™)	1
	B84654	icount Cable (Intelli-Cart™)	1
	B84224	icount Hoses (Intelli-Cart™)	2
	2/2A40EG4M-S	icount Fitting 1 (Intelli-Cart™)	2
	EMA3/1/8ED	icount Fitting 2 (Intelli-Cart™)	2

\*\*Refer to chart on How to Order page.

# Portable Filter Carts

## How to Order

Select the desired symbol (in the correct position) to construct a model code.

Example:

BOX 1	BOX 2	BOX 3	BOX 4	BOX 5	BOX 6	BOX 7	BOX 8
10MFP	2	40SA	10Q	B	VP	I	1

BOX 1: Basic Assembly	
Symbol	Description
5MFP	5 GPM (3000 SUS MAX.)
<b>10MFP</b>	<b>10 GPM (500 SUS MAX.)</b>

BOX 2: Length	
Symbol	Description
<b>2</b>	<b>Double</b>

BOX 3: Inlet Filter Element	
Symbol	Description
<b>40SA</b>	<b>Synthetic, 40 micron</b>
40W	Stainless Steel Mesh, 40 micron nominal
20Q	Microglass III, 20 micron

Please note the bolded options reflect standard options with a reduced lead-time. Consult factory on all other lead-time options.

BOX 4: Outlet Filter Element	
Symbol	Description
02Q	Microglass III, 2 micron
05Q	Microglass III, 5 micron
<b>10Q</b>	<b>Microglass III, 10 micron</b>
20Q	Microglass III, 20 micron
WR	Par-Gel™ Water Removal

BOX 5: Seals	
Symbol	Description
<b>B</b>	<b>Nitrile (NBR)</b>

BOX 6: Indicator	
Symbol	Description
<b>VP</b>	<b>Visual indicator, 3-band (mounted on Outlet Filter only)</b>

BOX 7: Bypass	
Symbol	Description
<b>I</b>	<b>35 PSID (2.4 bar) (outlet filter element)</b>

BOX 8: Options	
Symbol	Description
<b>1</b>	<b>None</b>
6*	20' electrical cord (retractable reel)
9	Visual indicator on Inlet Filter
PD**	iPD with standard LED Display
PDL**	iPD with LCD display and integrated Moisture Sensor

\* standard with option PD or PDL  
\*\* only available in 10MFP configuration

## Replacement Elements

Media	Nitrile Seals		Fluorocarbon Seals	
	Inlet Filter (3 psid integral bypass)	Outlet Filter (35 psid integral bypass)	Inlet Filter (3 psid integral bypass)	Outlet Filter (35 psid integral bypass)
02Q	N/A	937397Q	N/A	937405Q
05Q	N/A	937398Q	N/A	937406Q
10Q	N/A	937399Q	N/A	937407Q
20Q	940971Q	937400Q	940974Q	937408Q
40SA	940802	N/A	940972	N/A
40W	940803	N/A	940973	N/A
WR	N/A	940734	N/A	940736